

# SHACK MOUNTED DRILL RIG

## VD5000

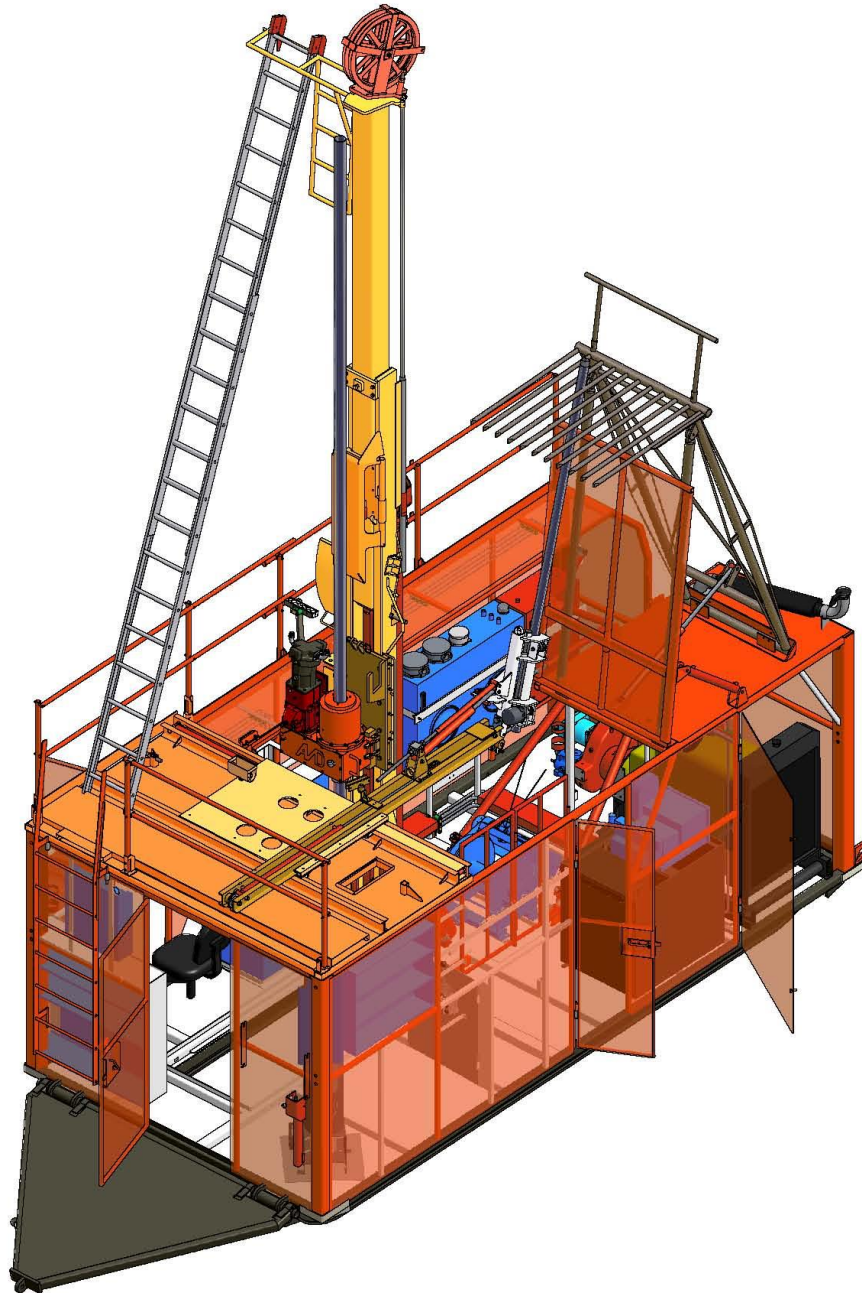

**Atelier  
Val-d'Or inc.**

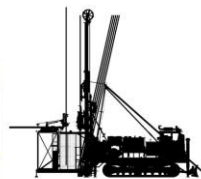

1096 Rue Léo-Fournier  
Parc Industriel  
Val-d'Or (Québec) J9P 6X8

☎ 819-824-3676  
☎ 819-824-2891  
✉ [ateliervd@ateliervd.qc.ca](mailto:ateliervd@ateliervd.qc.ca)

## STANDARD TECHNICAL SPECIFICATIONS

<b>Model</b>	VD5000
<b>Type</b>	Skid mounted, enclosed shack, all hydraulic chuck drive core drill, specially designed for diamond core drilling up to the rated specifications.
<b>Drill Mast</b>	Capacity to drill between 90° and 45°.
<b>Diesel Engine</b>	The most frequently used power units are John Deere 275HP JD6090 Tier3 or Cummins QSB6,7 Tier 3 with a normal operating speed up to 2,200 RPM (operating RPM can vary depending on pump configuration and option chosen).
<b>Fuel Tank Capacity</b>	160 litres (42 US gal.) + Fuel selector for the use of an auxiliary fuel tank
<b>Pump Drive</b>	<b>FUNK</b> triple pump drive (series 28000) with ratio 1.27:1 or 1:1
<b>Rotation Head</b>	AVD ( <b>Atelier Val D'Or</b> inc.) type with chain drive head for hydraulic chuck (customer choice) ratio 12/24 on "H" size head, and 12/29 on "P" size head.
<b>Transmission</b>	<b>FUNK</b> 4 speeds transmission (Ratio 1 <sup>st</sup> 6.63:1, 2 <sup>nd</sup> 3.17:1, 3 <sup>rd</sup> 1.72:1, 4 <sup>th</sup> 1:1)
<b>Head Table</b>	Hydraulic cylinder is directly coupled to the rotation head carriage. The travel is 3m (10ft) or 3.3m (11ft). At 4,200PSI, push capacity is 12,628 kg (27,832 lbs) and pull capacity is 23,947 kg (52,778 lbs).
<b>Pull Cylinder</b>	Hydraulic cylinder with 15,715 kg (34,636 lbs) of maximum pull at 4,200PSI, 26ft water swivel displacement.
<b>Water Pump</b>	Standard <b>BEAN</b> 435 or <b>PRATISSOLI</b> <b>KF40</b> (customer choice possible)
<b>Rod Clamp</b>	<b>BOYLES</b> style for "B" to "P" sizes.
<b>Wireline Winch</b>	Maximum capacity is 3,200m (10,498ft) for 3/16in wireline rope
<b>Hydraulic</b>	Full flow 25 micron Beta rated return oil filtration. Water/oil, air/oil hydraulically motorized (optional) and air/oil (optional, installed on the diesel engine) hydraulic coolers.
<b>Hydraulic Tank Capacity</b>	323 litres (85 US gal.)
<b>Maximum Pull Capacity</b>	39,662 kg (87,414 lbs) @ 4,200 PSI with feed and pull cylinder.
<b>Overall Weight of Drill</b>	approx. 14 519 kg (32 000 lbs)
<b>Rod Handler</b>	With Rollers Hand Configuration and HSS(Bolted Fingers) Rod Rack Comb for N,H and P.

**Rod Rack Maximum Stacking Capacity:**

Rod Size		<b>B (Ø2.19")*</b>	<b>N (Ø2.75")</b>	<b>H (Ø3.50")</b>	<b>P (Ø4.50")</b>
Qty (9-meter sections)		<b>308</b>	<b>204</b>	<b>130</b>	<b>80</b>
Depth in:	<b>meters</b>	2,772	1,836	1,170	720
	<b>feet</b>	9.094	6,024	3,839	2,362

\* : Optional B Add-On

**Atelier  
Val-d'Or inc.**



1096 Rue Léo-Fournier  
Parc Industriel  
Val-d'Or (Québec) J9P 6X8

☎ 819-824-3676  
☎ 819-824-2891  
✉ [ateliervd@ateliervd.qc.ca](mailto:ateliervd@ateliervd.qc.ca)

## STANDARD FEATURES

<b>Hoses Carriages</b>	Gortrac® Hoses Carriage For Drill Head Hoses and Rod Handler Hoses
<b>Anti-Noise Wall</b>	Noise Damping Wall Between Diesel Engine and Working Area
<b>Mast Dump</b>	24in Travel Mast Dump
<b>Extension Locking</b>	Allow Mast Extension Locking from Floor Level for Safety Purpose
<b>Water Swivel Slide</b>	Removable from Floor Level for Rod Handler Operation
<b>Remote Pulleys Greasing</b>	Allow Mast Pulleys Greasing from Floor Level
<b>LED Lightning</b>	Low Energy Consumption Lights
<b>Feed Cyl. Burst Valve</b>	Stops the Falling of the Head in Case of Hoses Failure

## OPTIONAL FEATURES

<b>Transport Wheels</b>	Heavy-Duty Wheels for Drill Transportation on Rocky Terrain
<b>Weatherproofing</b>	Insulated Walls and Doors for Heat Conservation and Noise Reduction
<b>Heated Floor</b>	Heated Floor and Floor Heating Units for Runner and Rod Handler Operator
<b>Hydraulic Heating Unit</b>	Supplementary Heating That Recycles the Heat of Hydraulic System
<b>RACOR Fuel Filter</b>	Efficient Filter Added on Engine Fuel Line
<b>Cyclone Air Filter</b>	Efficient Air Filter Added on Engine Air Intake
<b>AVD "P" Rod Clamp</b>	Eliminates the Need to Remove Jaws for Oversized Bits
<b>Interlocking Guards</b>	Isolates the Drill Mast and Limits Rotation at 50 RPM When Guard is Open
<b>Casing Breaker</b>	Hydraulic Device to Break Casing Joints
<b>Casing Clamp</b>	Clamp that Holds Casing Below the Rod Clamp, Eliminates the Use of Pipe Wrench
<b>Casing Puller</b>	Rod Clamp Mounted on a Sliding Base w/ Hydraulic Cylinders for Additional Pull Power
<b>Parallelogram Rod Comb</b>	Avoid Removal of Comb for Transport or Fingers Configuration Change
<b>Floor Pickup Rod Handler</b>	Pivoting Rod Handler. Can Handles Rods Stacked Horizontally in a Sloop

## OPTIONAL ELECTRO-HYDRAULIC DRILL FEATURES

<b>Proportional Valves</b>	Fully Proportional Danfoss Hydraulic Components
<b>LCD Display</b>	6.5" LCD Display for Parameters and Feedback (Pressures, Water Pump, Wireline Position)
<b>Compact Work Console</b>	With Levers and Buttons to Operates Drill Rig Functions
<b>Feedback Sensors</b>	Drill Head Position, RPM and Bit Weight Feedback on LCD Display
<b>Cameras</b>	Shows the Wireline on LCD Display at Activation of Wireline Function
<b>Data Recording</b>	Keeps History of Machine Parameters for Supervision/Troubleshooting
<b>Chuck/Clamp Synchro</b>	Automates the Operation of Chuck and Rod Clamp When Rod Pulling
<b>Automatic Pulling</b>	Automatically Pulls Rods in 3m, 6m or 9m Sections (Automates Feed + Chuck/Clamp)
<b>Automatic Drilling</b>	Drill Handles Drilling Automatically According to Set Parameters

**Atelier  
Val-d'Or inc.**



1096 Rue Léo-Fournier  
Parc Industriel  
Val-d'Or (Québec) J9P 6X8

☎ 819-824-3676  
☎ 819-824-2891  
✉ [ateliervd@ateliervd.qc.ca](mailto:ateliervd@ateliervd.qc.ca)

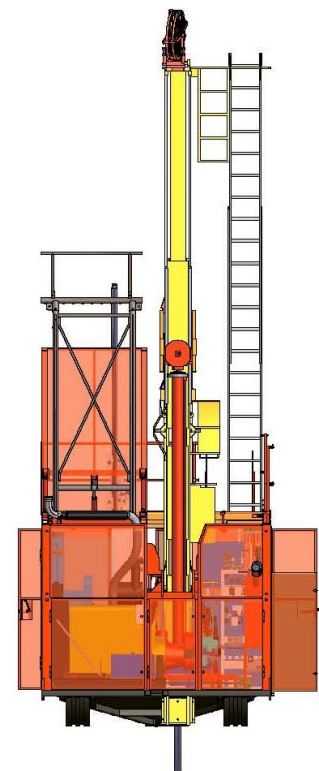
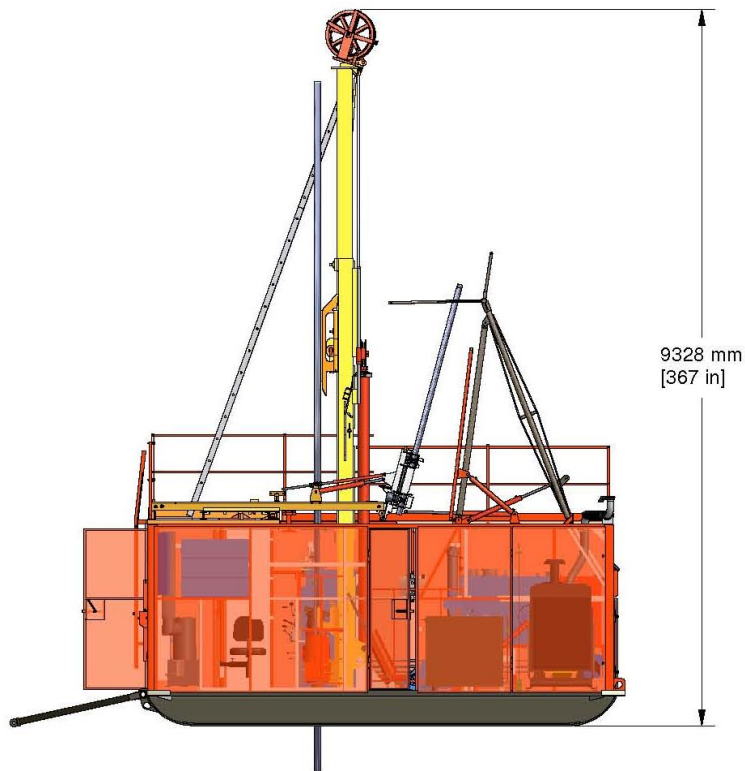
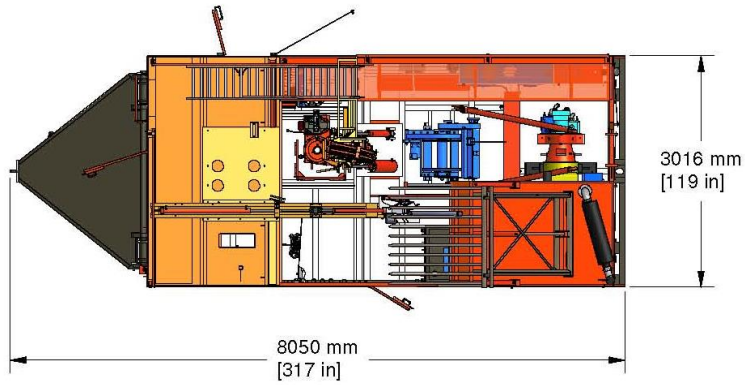

**DRILL IN WORKING POSITION (Mast Shown at 90°)**

**Atelier  
Val-d'Or inc.**

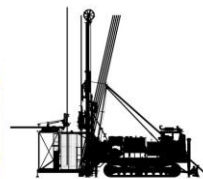

1096 Rue Léo-Fournier  
Parc Industriel  
Val-d'Or (Québec) J9P 6X8

☎ 819-824-3676  
☎ 819-824-2891  
✉ [ateliervd@ateliervd.qc.ca](mailto:ateliervd@ateliervd.qc.ca)

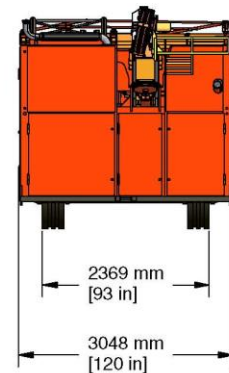
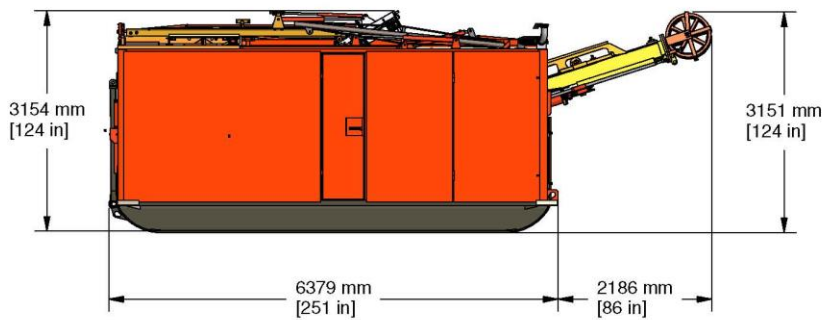
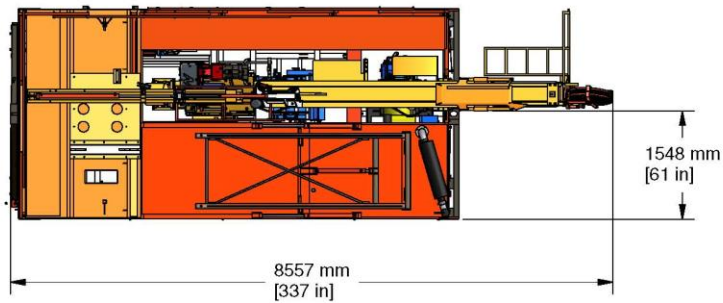
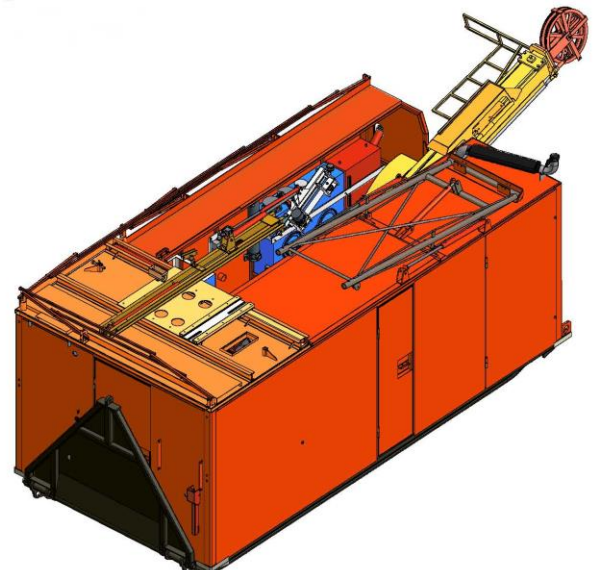

**DRILL IN TRANSPORT POSITION**

**Atelier  
Val-d'Or inc.**

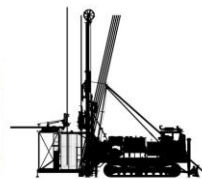

1096 Rue Léo-Fournier  
Parc Industriel  
Val-d'Or (Québec) J9P 6X8

☎ 819-824-3676  
☎ 819-824-2891  
✉ [ateliervd@ateliervd.qc.ca](mailto:ateliervd@ateliervd.qc.ca)